

FM Lüfterbefestigung

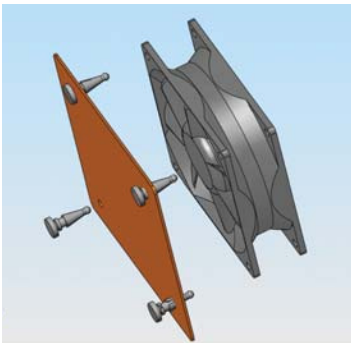

NEU

Bohrung-Lüfter: $\varnothing 5 \pm 1$
LP-Stärke Lüfter: Max. 2

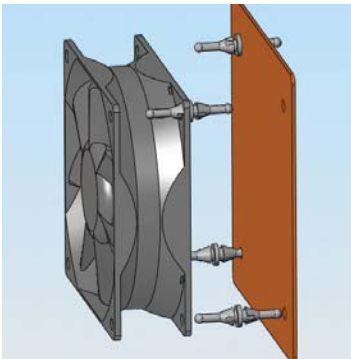
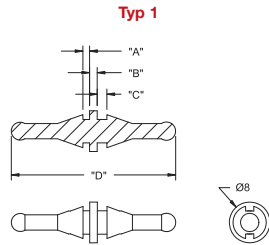

Bohrung-Lüfter: $\varnothing 5 \pm 1$
LP-Stärke Lüfter: Max. 1.4

Bohrung-Lüfter: $\varnothing 5 \pm 1$
LP-Stärke Lüfter: 3.1

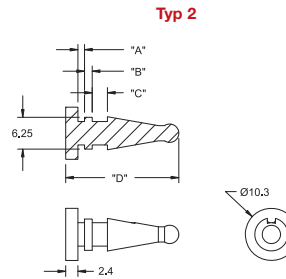

Bohrung-Lüfter: $\varnothing 5 \pm 1$
LP-Stärke Lüfter: Max. 1.4

Bohrung-Lüfter: \varnothing FM-5, 3.5 ± 1
FM-6, 4.3 ± 2
LP-Stärke Lüfter: FM-5, .20
FM-6, 15

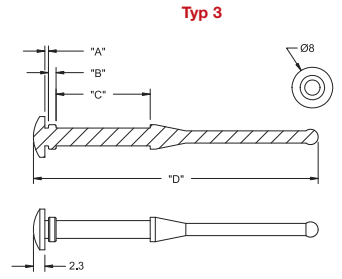

Bohrung-Lüfter: \varnothing FM-5, 3.5 ± 1
FM-6, 4.3 ± 2
LP-Stärke Lüfter: FM-5, .8 Max.
FM-6, 3 Max.

Eigenschaften

- Einfache Montage von Lüfter und Lüfterkomponenten

FM		VPE: 1.000 Stck.					
Artikel Bez.	Material	Farbe	"A"	"B"	"C"	"D"	Typ
FM-1	EPDM, 30 Shore A, RMS-166	Schwarz	1.3	1.5	1.9	32.3	1
FM-2	EPDM, 40,Shore A, RMS-180		1.3	1.5	1.9	32.3	
FM-3	EPDM, 30 Shore A, RMS-166		1.3	1.5	3	22.2	
FM-4	EPDM, 40,Shore A, RMS-180		1.3	1.5	3	22.2	2
FM-5	Silikon 30 Shore A, RMS-316		0.7	1.5	18.5	56	
FM-6	Silikon 30 Shore A, RMS-316		2.5	2	14	53.8	