

Tactile Switches

6x6 mm SMT Tactile Switches

TP32 Series

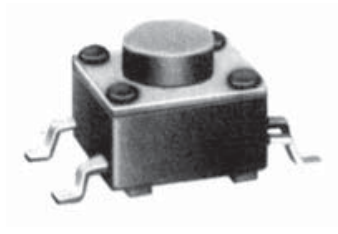

P.C.B MOUNTING PATTERN

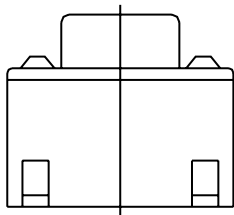
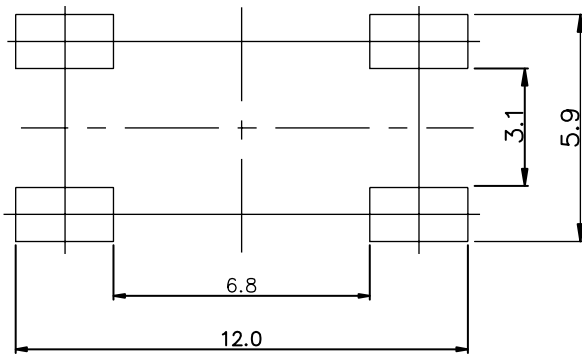

CIRCUIT DIAGRAM

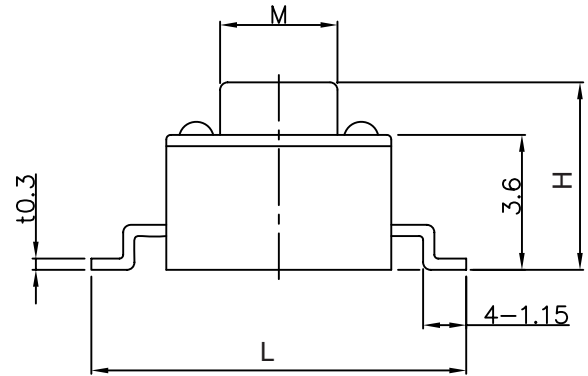
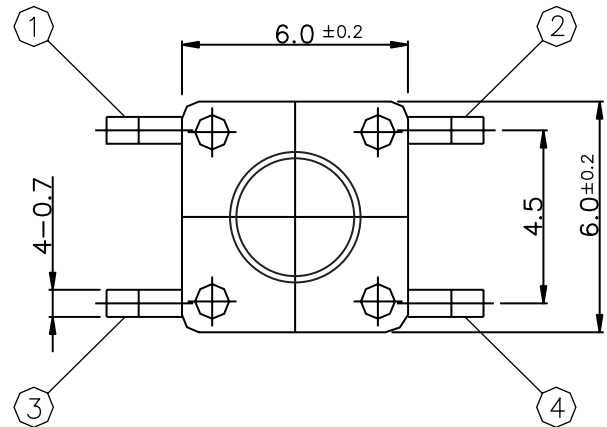
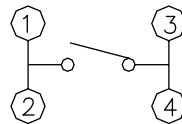

How to order:

TP32 ¹ ² ³ ⁴

1 KNOB HEIGHT "H":

Code	H	M
N	4.3 mm	3.4 mm
A	5.0 mm	3.4 mm
B	7.0 mm	3.4 mm
C	8.0 mm	3.4 mm
D	9.5 mm	3.3 mm
E	7.3 mm	3.3 mm
F	12.5 mm	3.3 mm
G	13.5 mm	2.8 mm
I	17.0 mm	2.8 mm
J	16.3 mm	2.8 mm
K	13.0 mm	3.3 mm
O	10.8 mm	3.05 mm
Q	9.7 mm	2.8 mm
R	8.5 mm	3.2 mm
X	18.1 mm	3.0 mm
Z	13.0 mm	2.8 mm

2 OPERATING FORCE & LIFE CYCLES:

Code	Operating Force	Life Cycles
100	100±30 gf	1,000,000
130	130±30 gf	1,000,000
160	160±50 gf	1,000,000
250	250±50gf	300,000
350	350±80 gf	200,000
500	500±100 gf	100,000

3 DIMENSION "L":

- 09 9mm
- 10 10mm

4 PACKAGING:

- BK Bulk
- TR Tape & Reel

Specifications:

- > Rating: 50mA 12VDC
- > Contact Resistance: 100mΩ Max.
- > Travel: 0.25±0.1 mm
- > Bounce: 10mSec. Max.

TOLERANCE UNLESS OTHERWISE STATED	
less than 10	±0.1
10~30	±0.2
30~100	±0.3
ANGLE	±2°

SPECIFICATIONS

1. General

- 1.1 Switch rating : DC 12V, 50mA
- 1.2 Operation temperature range : -20°C ~ 85°C
- 1.3 Preservative temperature range : -30°C ~ 85°C
- 1.4 Appearance and dimensions : See outside drawing page
- 1.5 Standard conditions : Unless otherwise specified, the test and measurements shall

be carried out as follows :

- Ambient temperature : 5 ~ 35°C
- Relative humidity : 45 ~ 85%RH
- Air pressure : 86 ~ 106kpa (860 ~ 1060mbar)

However, if doubt arises on the decision based on the measured values under the above-mentioned conditions, the following conditions shall be employed.

- Ambient temperature : 20±2°C
- Relative humidity : 65±5%RH
- Air pressure : 86 ~ 106kpa (860 ~ 1060mbar)

2. Performance

2.1 Electrical characteristics

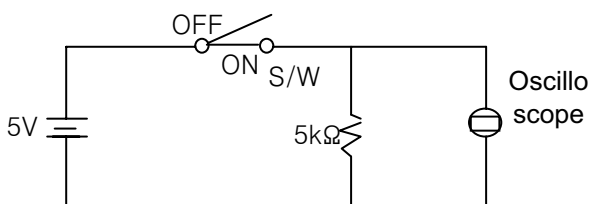
NO.	ITEMS	TEST CONDITIONS	PERFORMANCE
2.1.1	Contact Resistance	Applying a static load twice the actuating force to the center of the stem, measurements shall be made with a 1KHz small-current contact resistance meter.	100mΩ Max.
2.1.2	Insulation Resistance	Measurements shall be made following application of DC 100V potential across terminals and across terminals and frame for one minute.	100MΩ Min.
2.1.3	Dielectric Withstanding Voltage	AC 250V (50Hz or 60Hz) shall be applied across terminals and across terminals and frame for one minute.	There shall be no breakdown
2.1.4	Bounce	Lightly striking the center of the stem at a rate encountered in normal use (3 to 4 operation per sec.) bounce shall be tested at 'ON' and 'OFF' 	10msec Max.

2.2 Mechanical characteristics

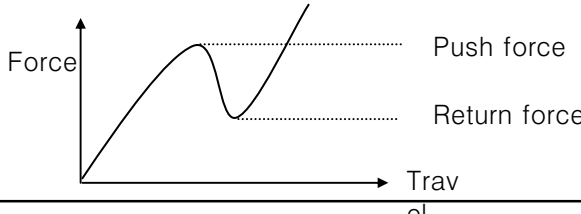
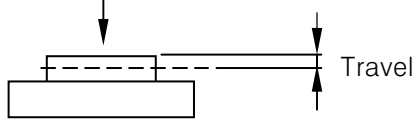
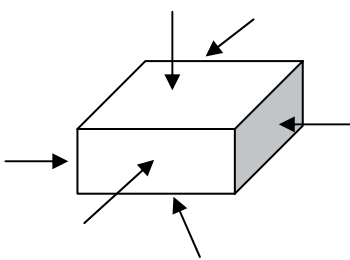
NO.	ITEMS	TEST CONDITIONS	PERFORMANCE
2.2.1	Operation Force	<p>Push by recommended operating condition</p>  <p>The graph shows Force on the vertical axis and Travel on the horizontal axis. A curve starts at the origin, rises to a peak labeled 'Push force', dips to a lower level labeled 'Return force', and then rises again.</p>	See outside drawing page
2.2.2	Travel	<p>Push by recommended operating condition</p> <p>$F = (\text{Operation force}) \times 2$</p>  <p>The diagram shows a cross-section of a tactile switch with a downward arrow indicating the push force and a vertical double-headed arrow indicating the travel distance.</p>	$0.25 \pm 0.1 \text{ mm}$
2.2.3	Stop Strength	A static load of 3kgf shall be applied in the direction of stem operation for a period of 60 seconds.	No damage (Electrical and Mechanical)
2.2.4	Vibration Test	<p>(1) Amplitude : 1.5mm</p> <p>(2) Sweep rate : 10-55-10Hz for 1 minute.</p> <p>(3) Sweep method : Logarithmic frequency sweep rate.</p> <p>(4) Vibration direction : X.Y.Z (3 directions).</p> <p>(5) Time : Each direction 2 hours (Total 6 hours).</p>	No. 2.1 and 2.2.1 to 2.2.2 shall be satisfied.
2.2.5	Impact Shock Test	<p>(1) Acceleration : 50G</p> <p>(2) Cycles of test : 3 cycles each in 6 directions for a total 18 cycles.</p>  <p>The diagram shows a 3D perspective of a rectangular tactile switch with arrows pointing to its top, bottom, front, and back surfaces, indicating the directions of impact.</p>	No. 2.1 and 2.2.1 to 2.2.2 shall be satisfied.
2.2.6	Soldering heat test	<p>Soldering area : $t/2$ of P.W.B thickness (P.W.B : $t = 1.6$)</p> <p>Soldering temperature : $260 \pm 5^\circ\text{C}$</p> <p>Soldering time : $5 \pm 1 \text{ sec}$</p>	No damage (Electrical and Mechanical)

2.3 Climatic characteristics

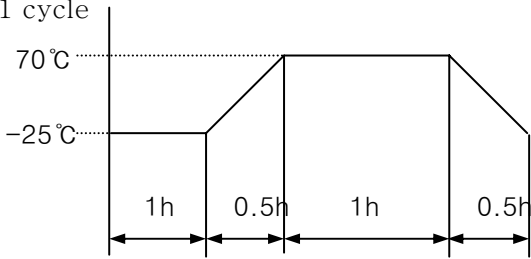
NO.	ITEMS	TEST CONDITIONS	PERFORMANCE
2.3.1	Cold test	(1) Temperature : $-30\pm 2^{\circ}\text{C}$ (2) Duration of test : 96 hours (3) Take off a drop water (4) Standard conditions after test : 1 hour	Contact Resistance : $200\text{m}\Omega$ max. No. 2.1.2 to 2.1.4 & 2.2.1 to 2.2.2 shall be satisfied.
2.3.2	Heat test	(1) Temperature : $85\pm 2^{\circ}\text{C}$ (2) Duration of test : 96 hours (3) Standard conditions after test : 1 hour	Contact Resistance : $200\text{m}\Omega$ max. No. 2.1.2 to 2.1.4 & 2.2.1 to 2.2.2 shall be satisfied.
2.3.3	Temperature Cycle	(1) Test cycles : 5 cycles (2) Standard conditions after test : 1 hour (3) 1 cycle 	Contact Resistance : $200\text{m}\Omega$ max. No. 2.1.2 to 2.1.4 & 2.2.1 to 2.2.2 shall be satisfied.
2.3.4	Humidity Test	(1) Temperature : $60\pm 2^{\circ}\text{C}$ (2) Relative humidity : 90 ~ 95% (3) Duration of test : 96 hours (4) Take off a drop water (5) Standard conditions after test : 1 hour	Contact Resistance : $200\text{m}\Omega$ max. No. 2.1.2 to 2.1.4 & 2.2.1 to 2.2.2 shall be satisfied.
2.3.5	Operating Life Test	(1) DC 5V, 5mA Resistance load (2) Operation speed : 2 ~ 3 cycles/sec (3) Push force : Maximum value of operation force (4) Cycles of operation : See outside drawing page	Contact Resistance : $200\text{m}\Omega$ max. Bounce : 20m sec max. Operating force : initial value $\pm 30\%$ No. 2.1.2 to 2.1.3 & 2.2.2 shall be satisfied.
2.3.6	Salt mist test	Switch shall be checked after following test. (1) Temperature : $35\pm 2^{\circ}\text{C}$ (2) Salt solution : $5 \pm 1\%$ (3) Duration of test : 48 hours	Without excessive rust or discoloration

3. Soldering

3.1 Reflow soldering conditions

Preheat : Temperature on the copper foil surface should reach 180°C, 120 sec(max) after the P.W.B entered into the soldering equipment.

Soldering heat : Temperature on there copper foil surface should reach the peak temperature of 260°C within 40 seconds after the P.W.B(t=1.6mm) entered into soldering heat zone.

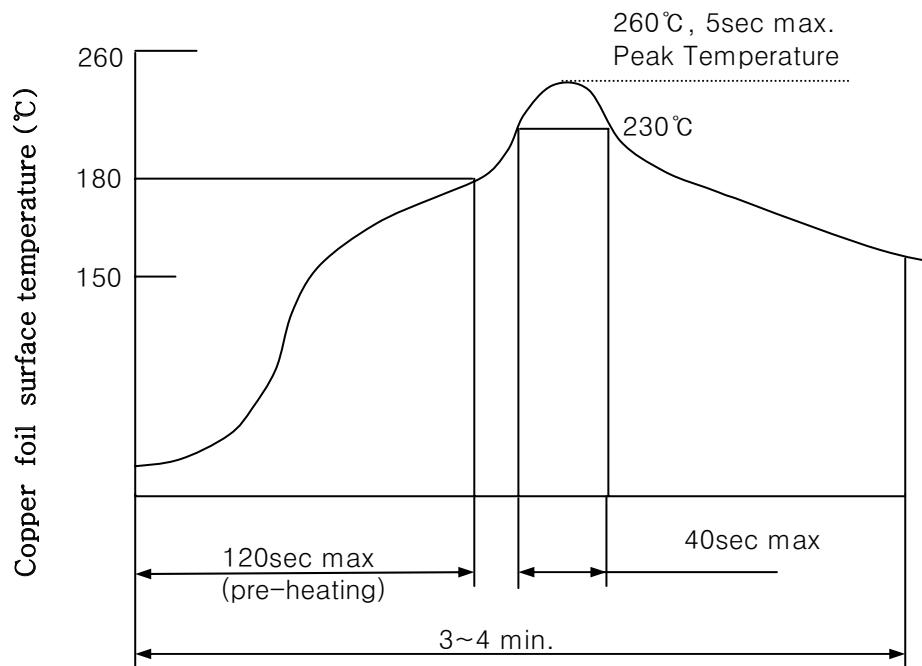

Temperature Profile

1. Scope

This specification covers the requirement of the tapping packaging for TP32 TACT switches.

2. Packaging Materials

Item	Description
Package	Cartons
Reel	core : Formed polystyrene sideboard : Polystyrene
Carrier tape	Polystyrene
Cover	Polyester

3. Packing Quantity

3.1 The number of the reels.

10 reels at maximum, which contain 10,000 switches shall be packed in a package.

3.2 The number of the switches.

1,000 switches shall be packed in a reel.

4. Tape Form and Dimensions

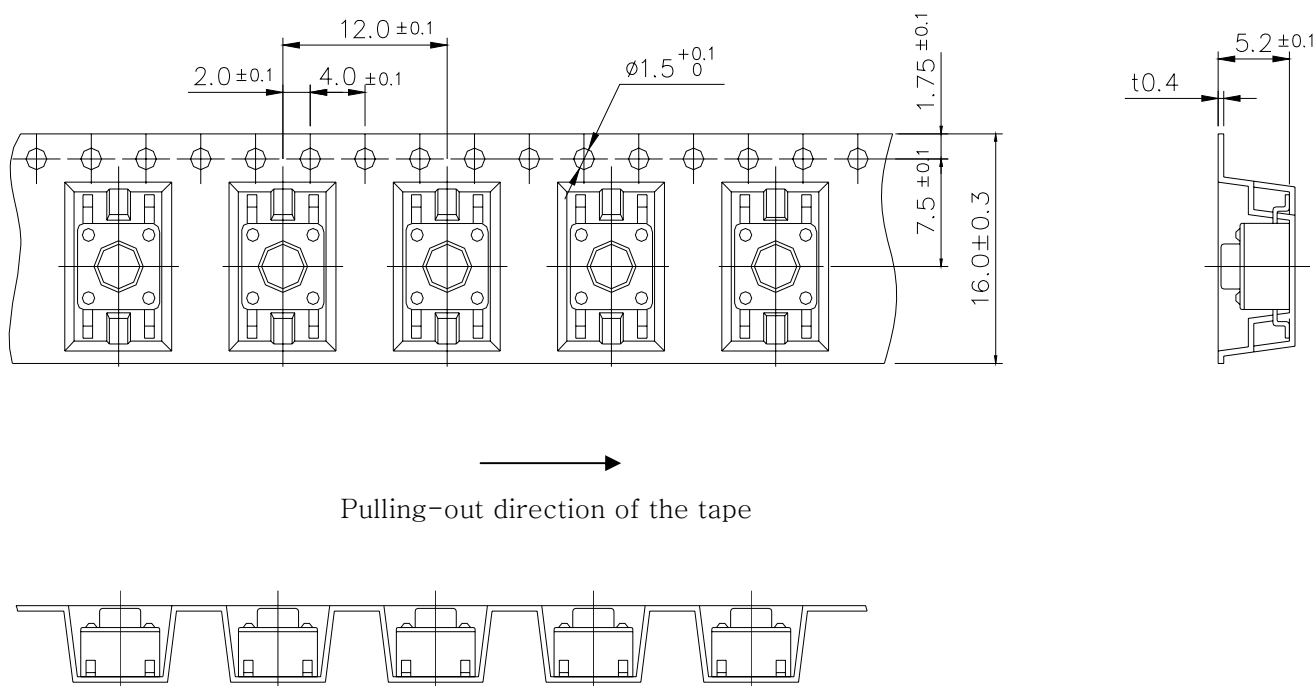

5. Reel Form and Dimensions

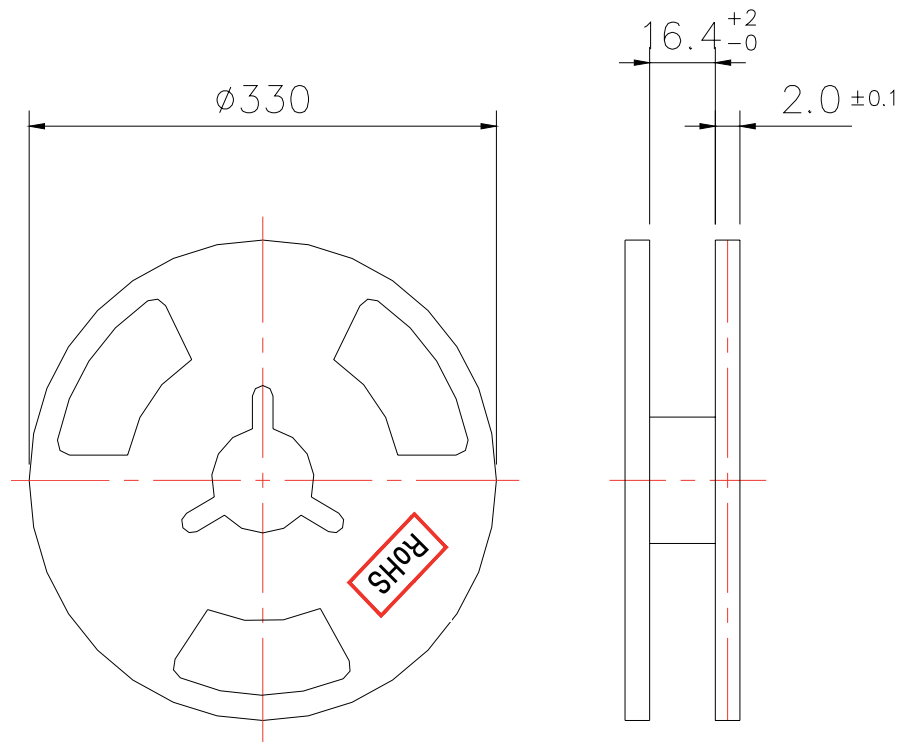

6. Packing Procedure

- 6.1 At the beginning of reeling, the end of the tape, 200mm or more, shall be empty and fit into the groove in the reel core.
- 6.2 After reeling, the end of the tape, 130 ± 4 mm, shall be empty and the tape edge shall cut in 45° the cover tape shall be extended 250 ± 10 mm from the tape edge and fixed with tape
- 6.3 Total number of missing switches shall be less than 10 in one reel.
(Three consecutive switches may be missing)

7. Storage Condition

- 7.1 Storage environment : $-20^\circ\text{C} \sim +50^\circ\text{C}$, 20% ~ 85% RH.
(Storage in high temperature and high humidity shall be avoided)